

COMMERCIAL FITNESS BIKES

R70

VISION FITNESS

Assembly Guide

VISION FITNESS



vision
it all
starts
with a

1620 Landmark Drive • Cottage Grove, WI 53527
Toll Free 800.335.4348 • Fax 608.839.8731
www.visionfitness.com
©2009 Vision Fitness. All Rights Reserved. 11.06
AG1814FR20
REV1

TOOLS & PARTS INCLUDED

5mm T-Shaped Wrench

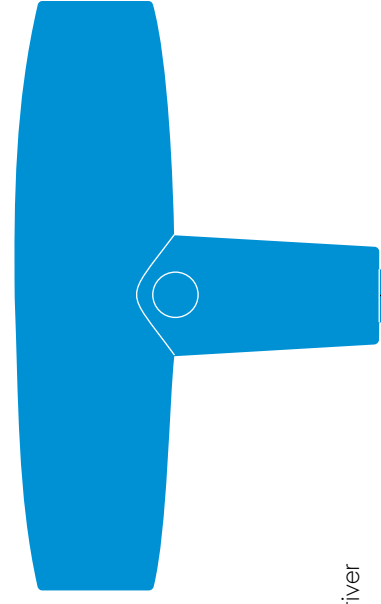

Screwdriver

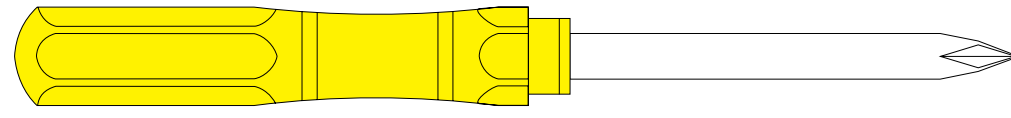

4mm L-Shaped Wrench

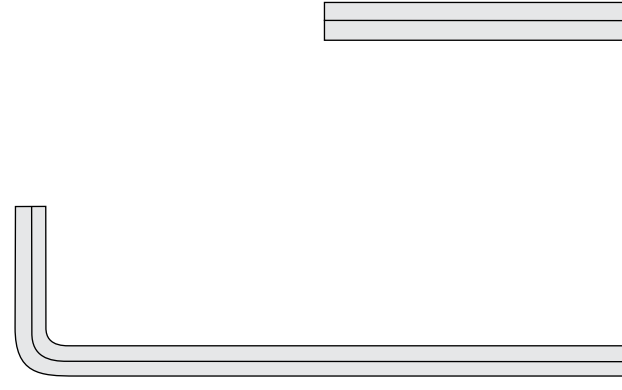

1.5mm Pedal Wrench

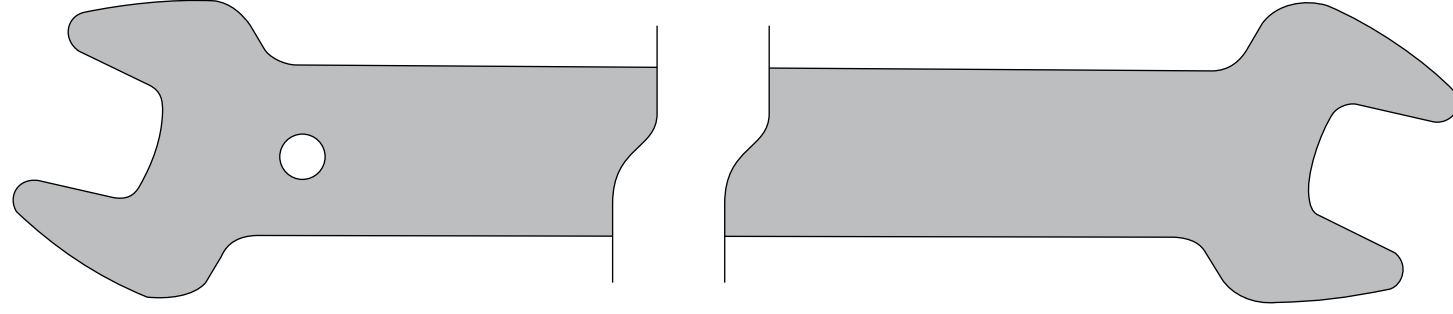

5mm L-Shaped Wrench

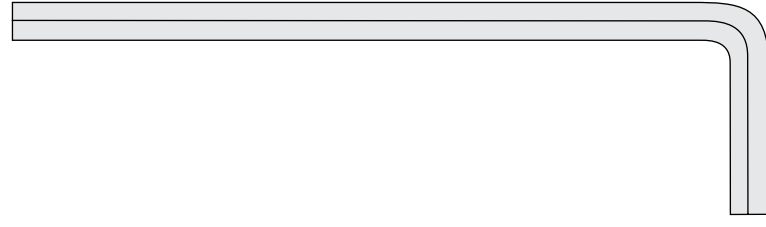

PARTS BOX

- Console Mast Cover
- Water Bottle
- Heart Rate Chest Strap
- Color-coded Hardware Bags
- Pedals/Straps
- Owner's Guide
- Assembly Guide
- Warranty Card

HARDWARE INCLUDED

ORANGE BAG

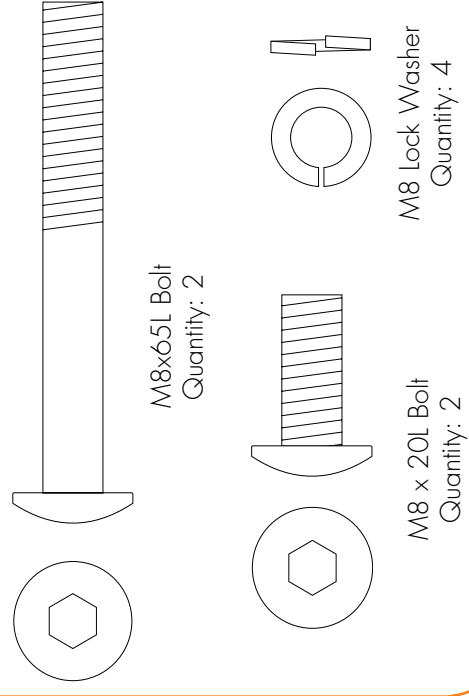

GREEN BAG

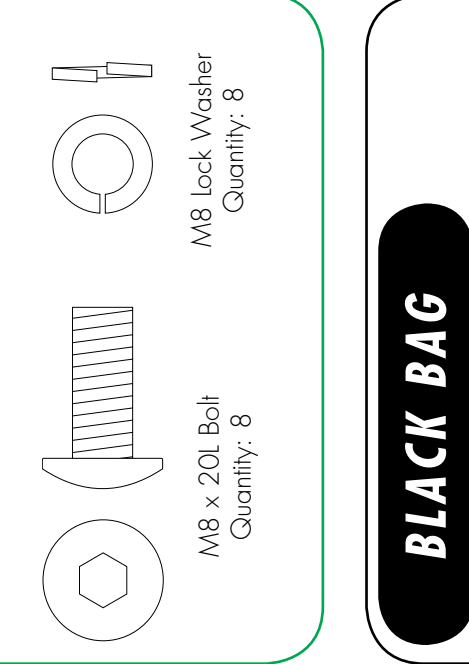

BLUE BAG

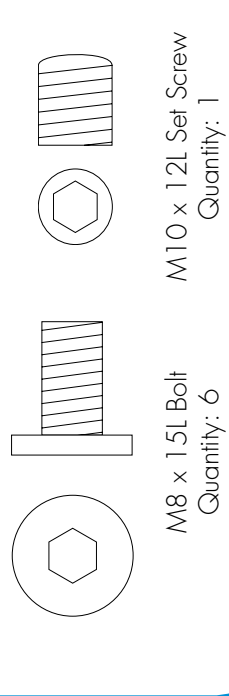

BLACK BAG

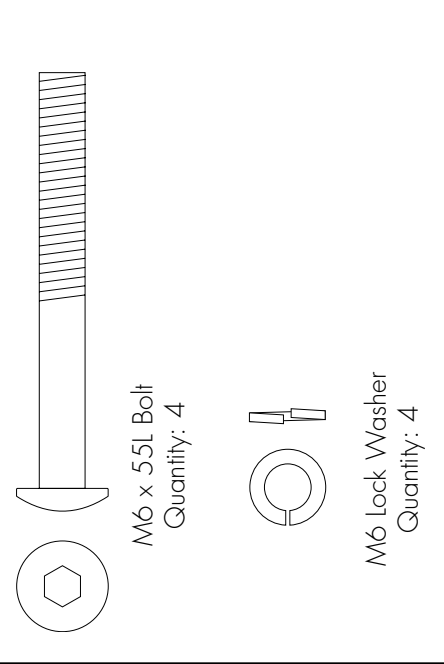

PINK BAG

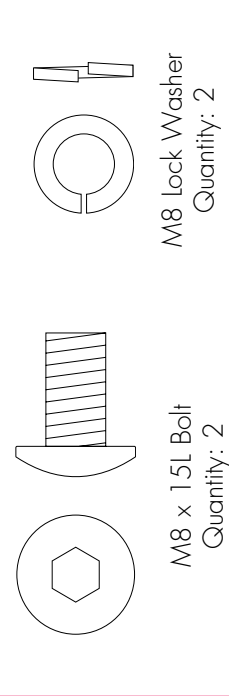

YELLOW BAG

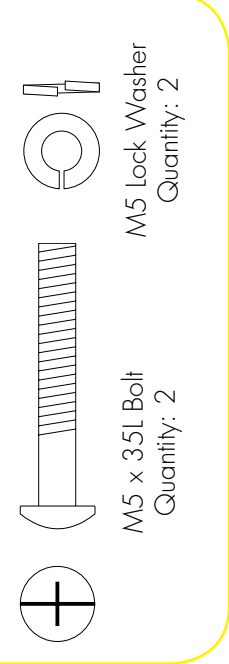

Assembly Guide

R70 COMMERCIAL FITNESS BIKES

To avoid possible damage to this Fitness Bike, please follow these assembly steps in the correct order. Before proceeding, find your new Fitness Bike's serial number located on the front axle tube, and enter here:

Refer to this number when calling for service, and enter this serial number on your Warranty Card and in your own records. Be sure to read your Owner's Guide before using your new Fitness Bike. If any parts, hardware or tools are missing, please call 1.800.335.4348, Extension 12

NOTE: It is recommended that you apply grease to the threads of each bolt and screw as you assemble your Fitness Bike to prevent loosening and noise. Also, during each assembly step, ensure that ALL screws and bolts are in place and partially threaded in before completely tightening any ONE screw or bolt.

STEP 1 ORANGE BAG

- Install the rear foot with the four lock washers (M8), two inside bolts (M8x65L), and two outside bolts (M8x20L). Tighten with the 5mm T-Shaped wrench.

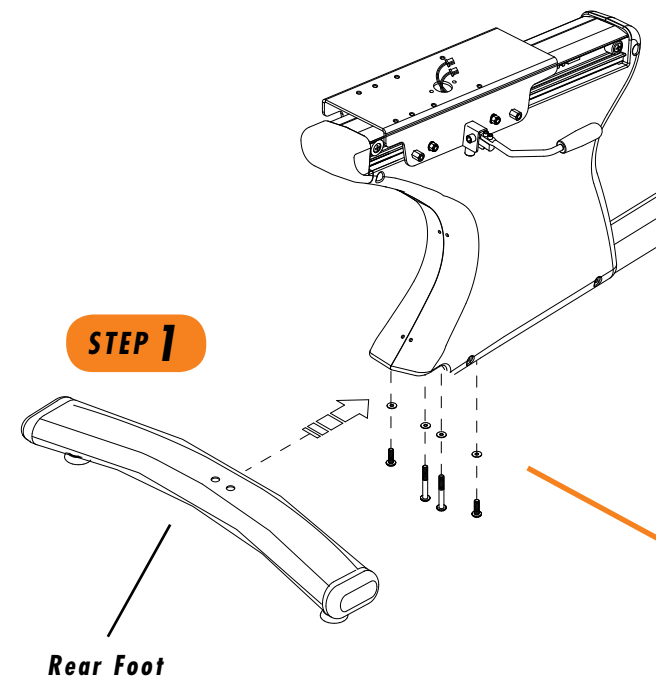

STEP 2 BLUE BAG

- Slide the console mast boot onto the console mast.
- Unfold the wire harness and heart rate wires located in the console mast frame bracket. Attach the wire tie coming from the bottom of the console mast to the wire harness and heart rate wires. Pull the wire tie with wire harness and heart rate wires up through the top of the console mast while simultaneously sliding the mast into the frame bracket.
- Secure the console mast to the frame bracket with six bolts (M8x15L). Tighten with the 5mm T-Shaped wrench. Insert a set screw (M10x12L) to the front edge of the mast and tighten until snug with the 5mm T-shaped wrench.
- Slide the console mast boot down and snap it into place on the side cover.

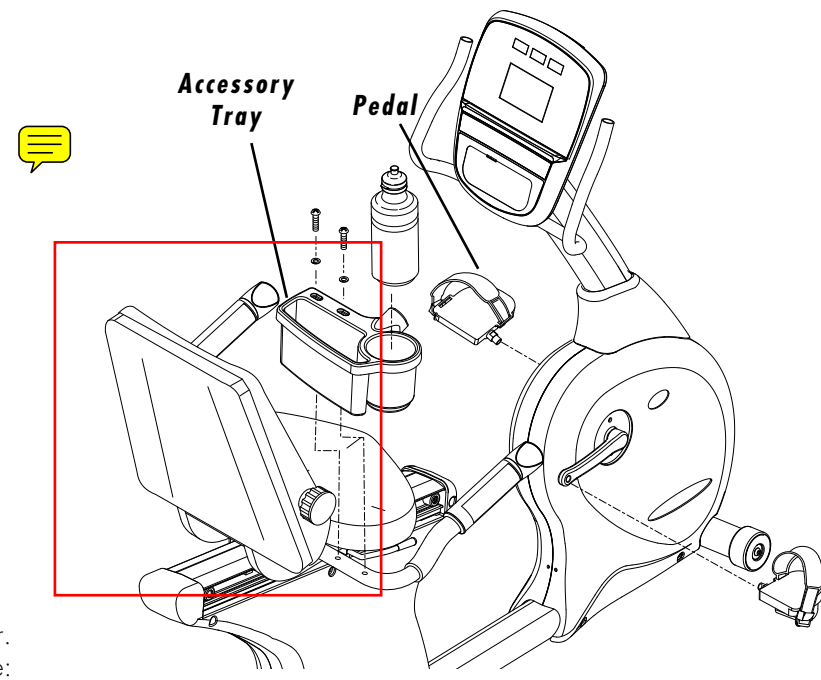
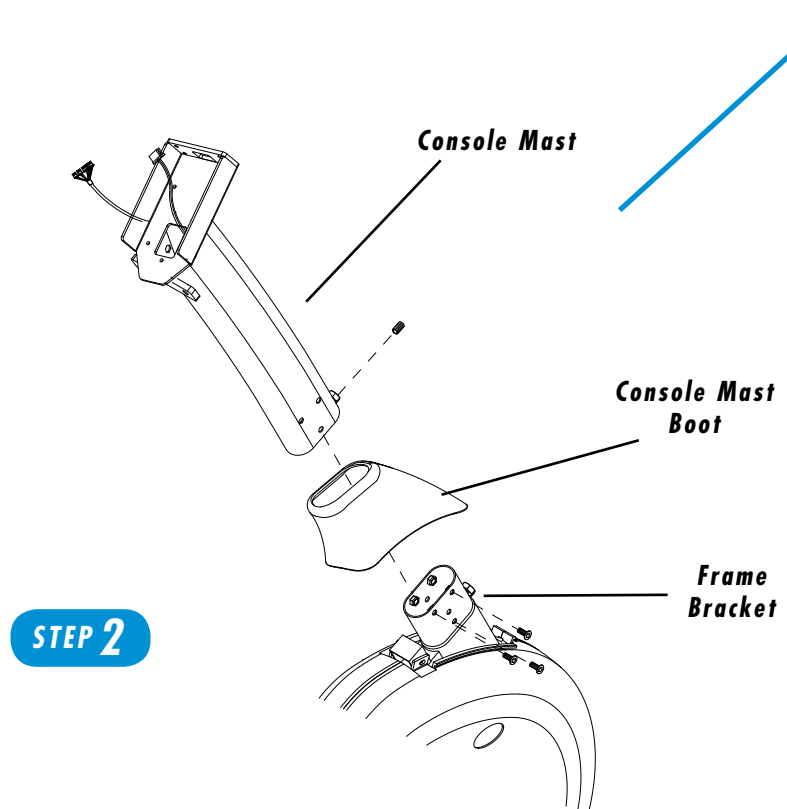

STEP 6

STEP 5

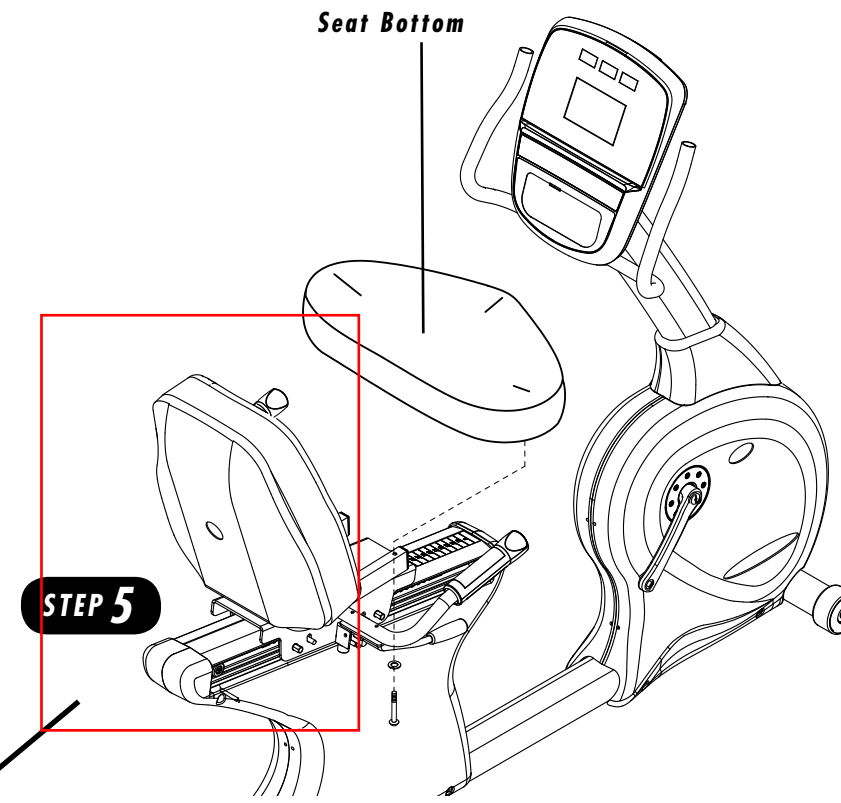

STEP 3

PINK BAG

- Mount the upper handlebars to the console mast using two lock washers (M8) and two bolts (M8x15L). Tighten with the 5mm T-Shaped wrench.
- Remove the four mounting screws from the back of the console. Remove the four console back cover screws. Connect the wire harness and heart rate wires that come from the console mast into the plugs located in the back of the console. Attach the console to the mast with the four screws removed earlier.
- Plug in the 9-volt battery. Re-attach the console back cover with the four screws previously removed.

STEP 4

GREEN BAG

- Remove the two socket head bolts from the sliding seat adjustment bracket. Slide the seat adjustment handle between the teeth of the seat adjustment bracket. Reinsert the two socket head bolts and tighten with the 4mm L-shaped wrench.
- Attach the seat frame to the sliding seat bracket using four lock washers (M8) and four bolts (M8x20L) and the 5mm T-Shaped wrench.
- Connect Wires A on the seat handlebar to Wires B on the sliding seat bracket. Connect the wire harness coming from the seat frame to the wire harness in the handlebars. Attach the seat handlebars to the sliding seat bracket using four lock washers (M8) and four bolts (M8x20L). Tighten with the 5mm T-Shaped wrench.

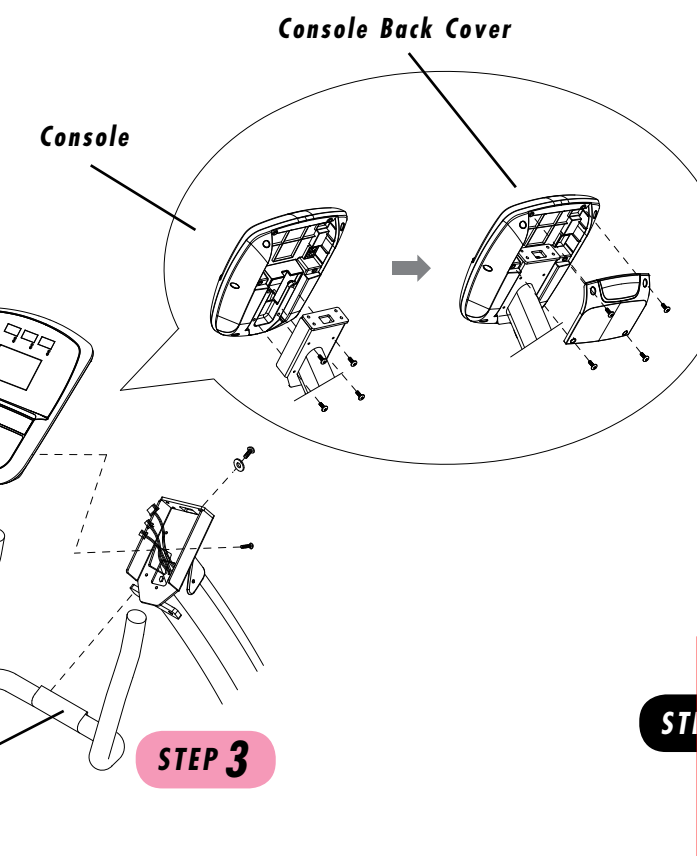

STEP 5

BLACK BAG

- Mount the seat bottom and seat back to the seat frame with four bolts (M6x55L) and four lock washers (M6). Tighten with the 4mm L-shaped wrench.

STEP 6

YELLOW BAG

- Attach the left and right pedals to the left and right crank arms. Tighten the pedals using the 15mm Pedal Wrench.
- Secure the Accessory Tray to the seat handlebar with two bolts (M5x35L) and two lock washers (M5). Be careful when inserting the bolts to clear the wires inside the handlebar to prevent damage. Tighten with the screwdriver.

