

COMMERCIAL ELLIPTICAL TRAINERS

X70

VISION FITNESS

Assembly Guide

500 South CP Avenue • P.O. Box 280 • Lake Mills, WI 53551
 Toll Free 800.335.4348 • phone 920.648.4090 • fax 920.648.3373
 www.visionfitness.com
 ©2008 Vision Fitness. All Rights Reserved. 3 08
 K74

8mm LShaped Wrench

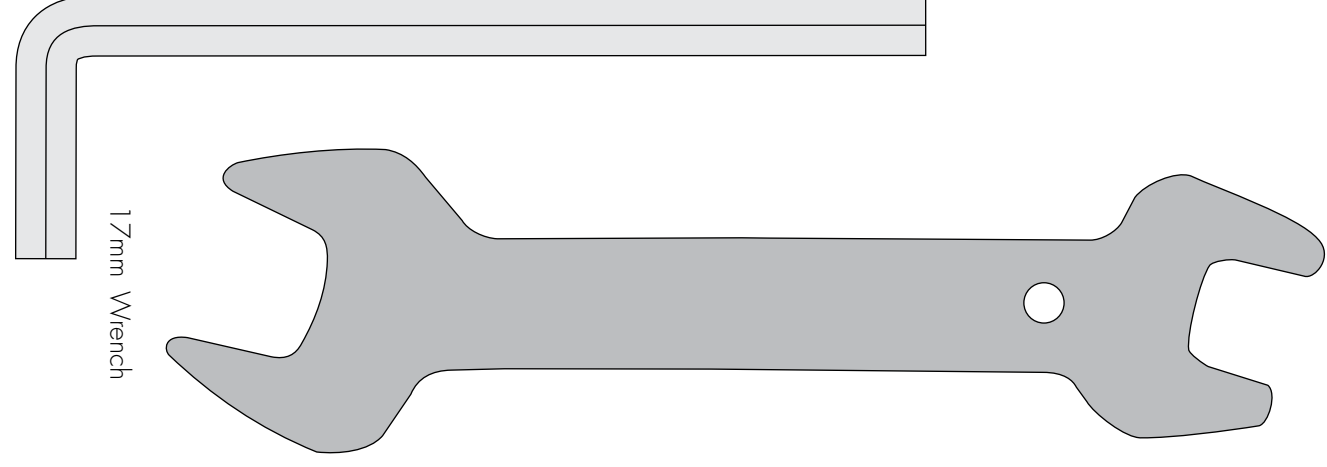

17mm Wrench

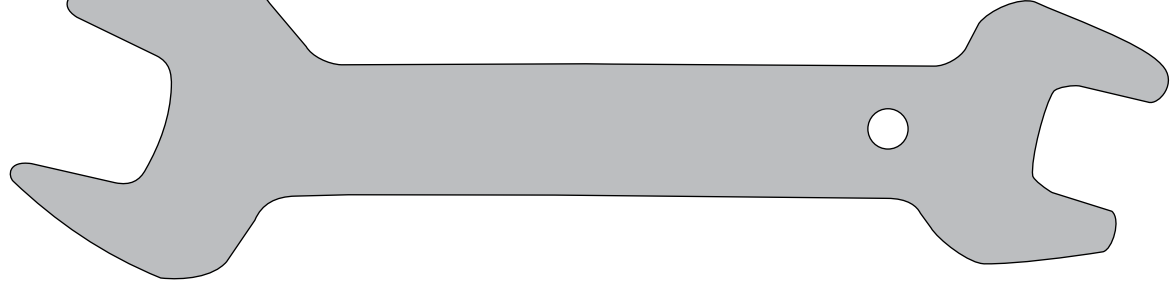

13mm Wrench

5mm LShaped Wrench

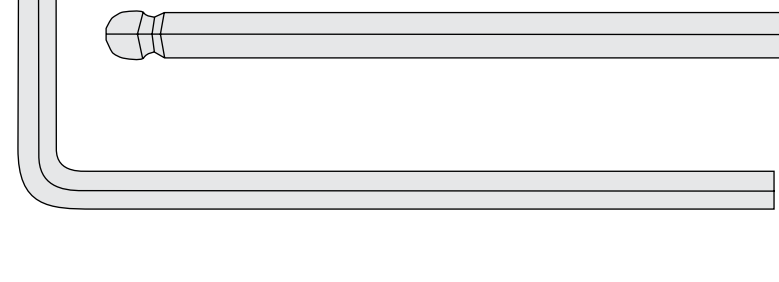

6mm LShaped Wrench

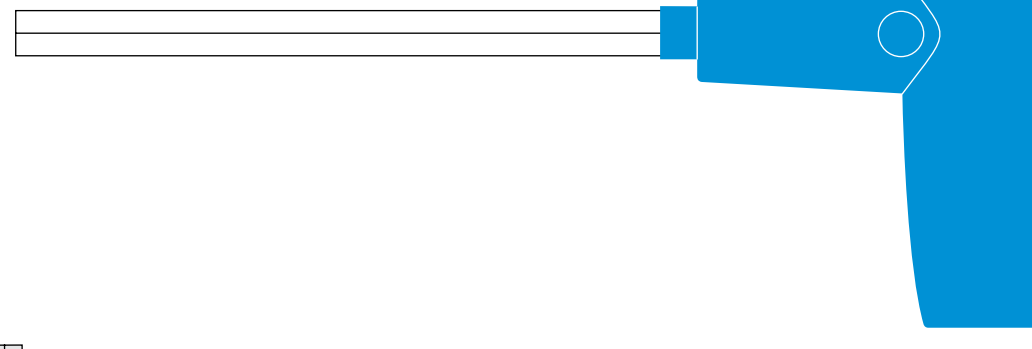

6mm TShaped Wrench

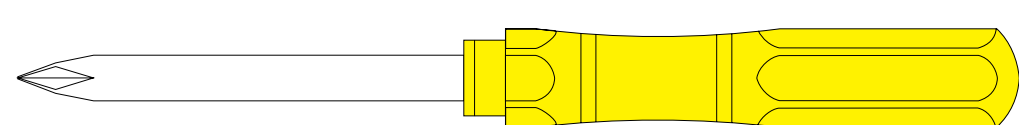

Screwdriver

PARTS BOX

Power Cord
 Console Mast Bracket
 Console Mast Cover
 Accessory Tray
 Owner's Guide
 Assembly Guide
 Warranty Card

X70

COMMERCIAL ELLIPTICAL TRAINERS

To avoid possible damage to this Elliptical Trainer, please follow these assembly steps in the correct order. Before proceeding, find your new Elliptical Trainer's serial number located on the frame, and enter here:

Refer to this number when calling for service, and enter this serial number on your Warranty Card and in your own records. Be sure to read your Owner's Guide before using your new Elliptical Trainer.
If any parts, hardware or tools are missing, please call your local dealer.

NOTE: It is recommended that you apply grease to the threads of each bolt and screw as you assemble your Elliptical Trainer to prevent loosening and noise. Also, during each assembly step, ensure that ALL bolts and screws are in place and partially threaded in before completely tightening any ONE bolt or screw.

HARDWARE INCLUDED

PINK BAG

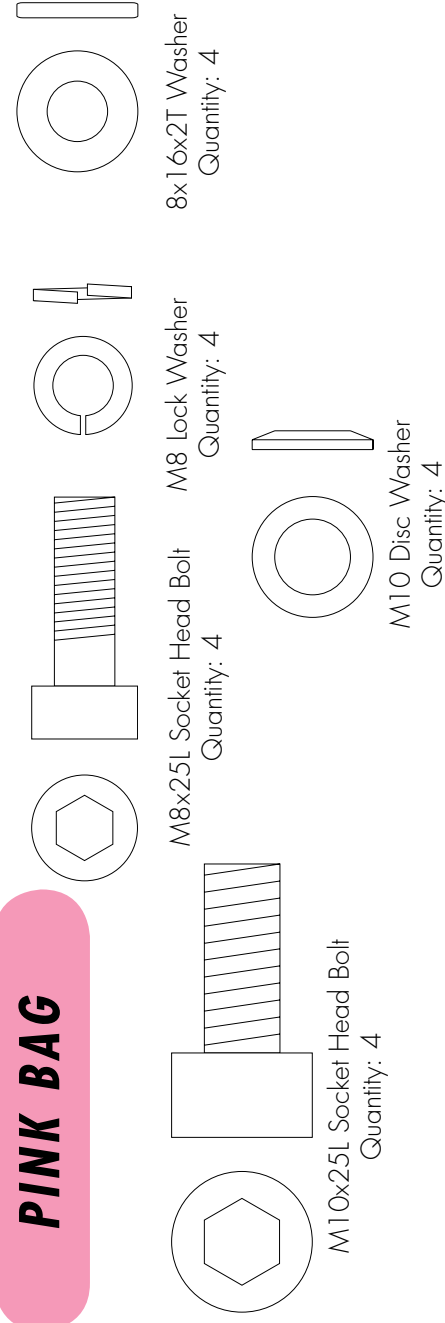

BLUE BAG

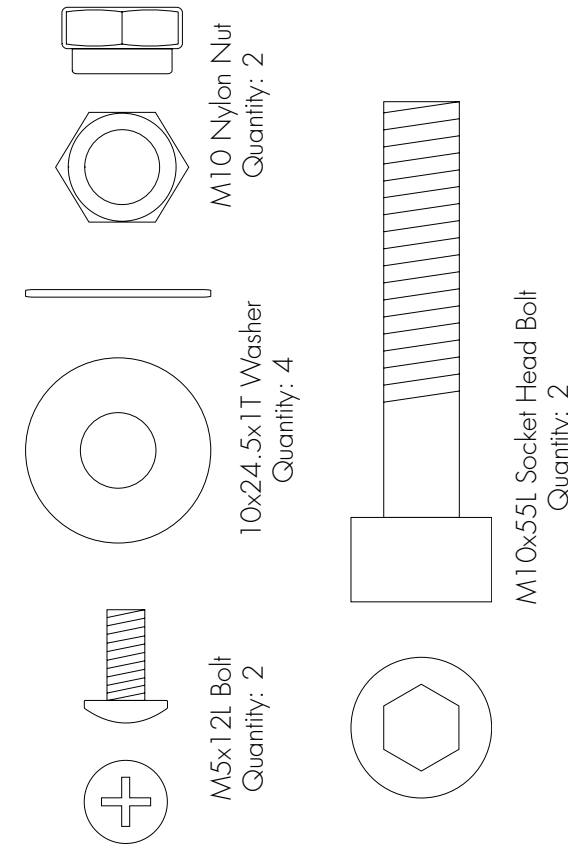

ORANGE BAG

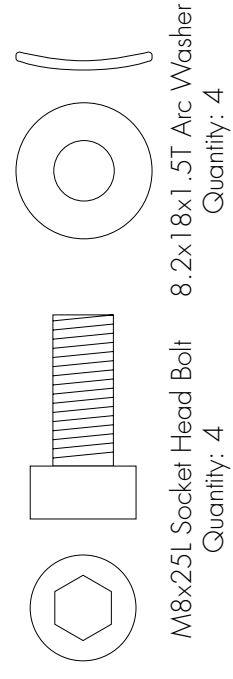

GREEN BAG

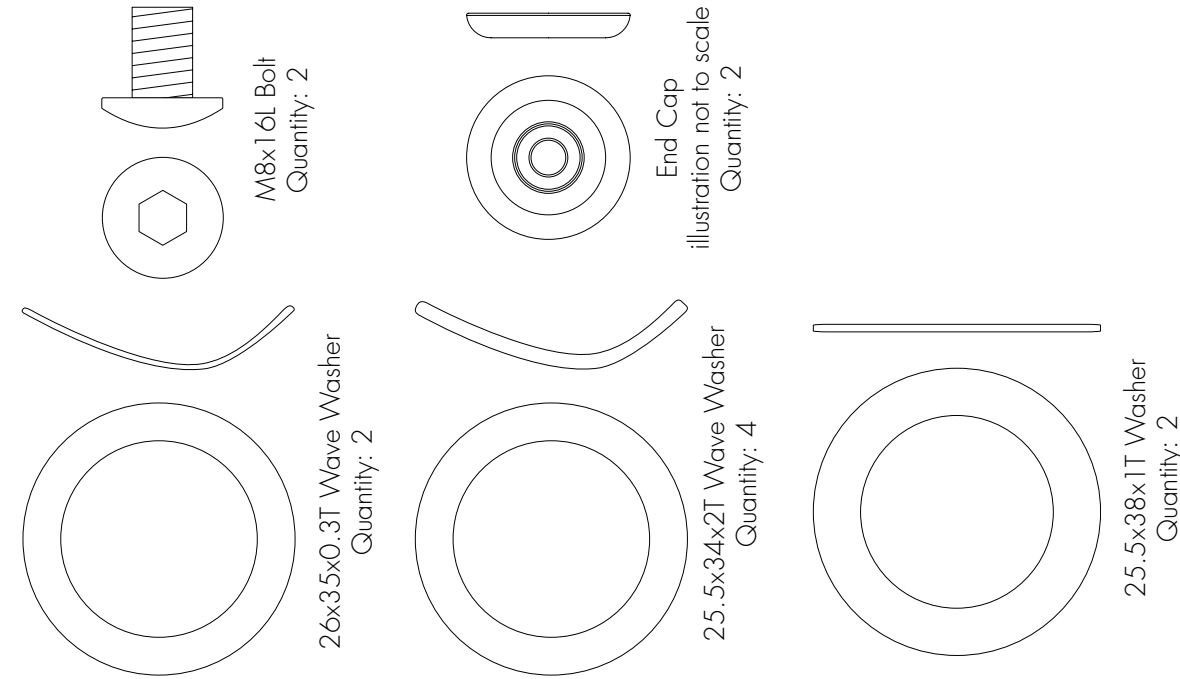

HARDWARE INCLUDED

BLACK BAG

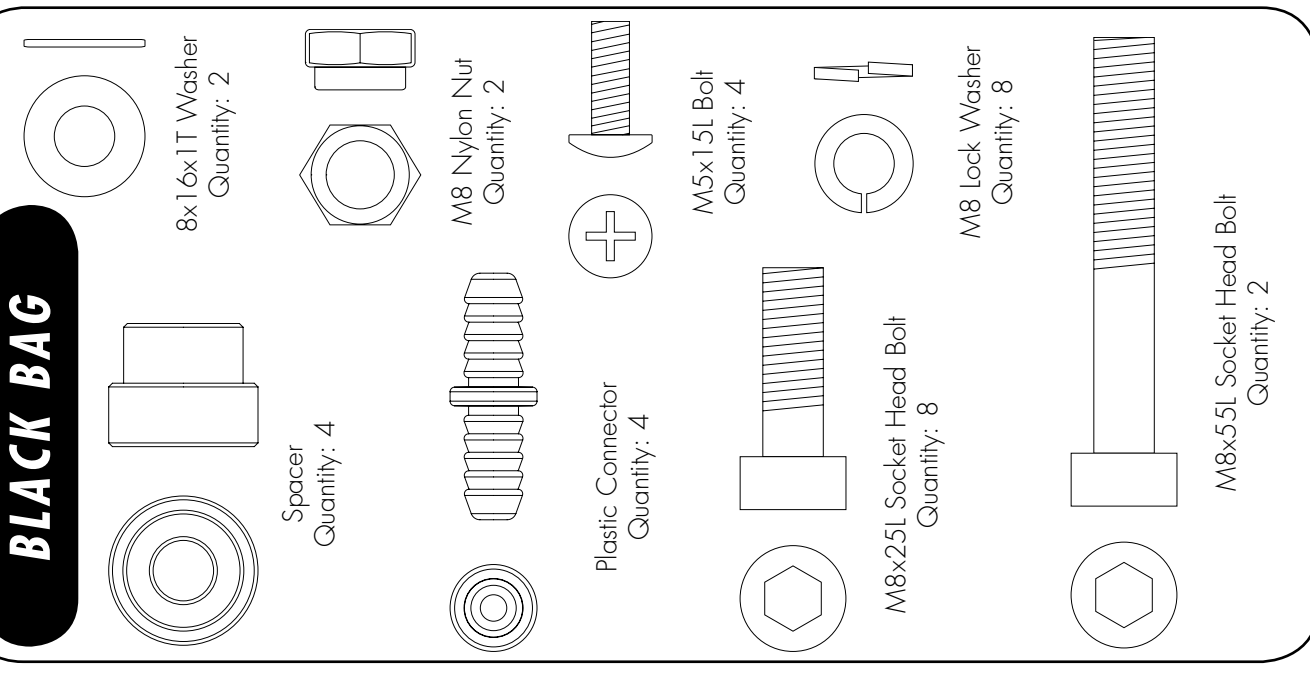

YELLOW BAG

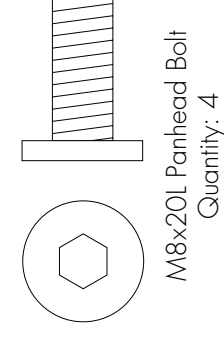

STEP 1 ORANGE BAG

- Place a piece of packaging under the front of the unit to aid in assembly of the front foot.
- Secure the front stabilizer tube to the base frame plate with four socket head bolts (M8x25L) and four arc washers (8.2x18x1.5T). Tighten with the 6mm L-shaped wrench.
- Remove the packaging from under the front of the unit.

STEP 2 BLUE BAG

- Take the right pedal arm and set the roller wheel in the aluminum guide track. Slide the opposite end of the pedal arm into the U-shaped knuckle bracket. Slide a socket head bolt (M10x55L) with a washer (10x24.5x1T) through the hole in the knuckle bracket and pedal arm. Fix in place with a washer (10x24.5x1T) and nylon nut (M10). Tighten with the 8mm L-shaped wrench and the 17mm wrench.
- Slide the pedal arm cover over the knuckle joint and fix in place with a bolt (M5x12L). Tighten with the screwdriver.
- Repeat these steps on the left side.

STEP 3 PINK BAG

- Slide the console mast boot onto the console mast.
- Attach the mounting plate to the bottom of the console mast with four socket head bolts (M10x25L) and four disc washers (M10). Tighten as much as possible with the 8mm L-shaped wrench.
- Mount the console mast on the frame by sliding the guide hole on the mast mounting plate over the guide screw on the front of the frame bracket. Place a lock washer (M8) followed by a flat washer (8x16x2T) on each of the four remaining socket head bolts (M8x25L). Insert the bolts to the rear holes but do not completely tighten. Next, insert the bolts to the front holes. Tighten all four bolts as much as possible with the 6mm L-shaped wrench.
- Wrap the wire tie that exits the hole at the bottom front side of the console mast around the wire harness coming up from the frame. Pull the wire tie and wire harness up through the top of the console mast.
- Insert a zip tie through the hole in the middle of the console plate and loop it around the heart rate wires and wire harness. Pull to snug, but do not over tighten.

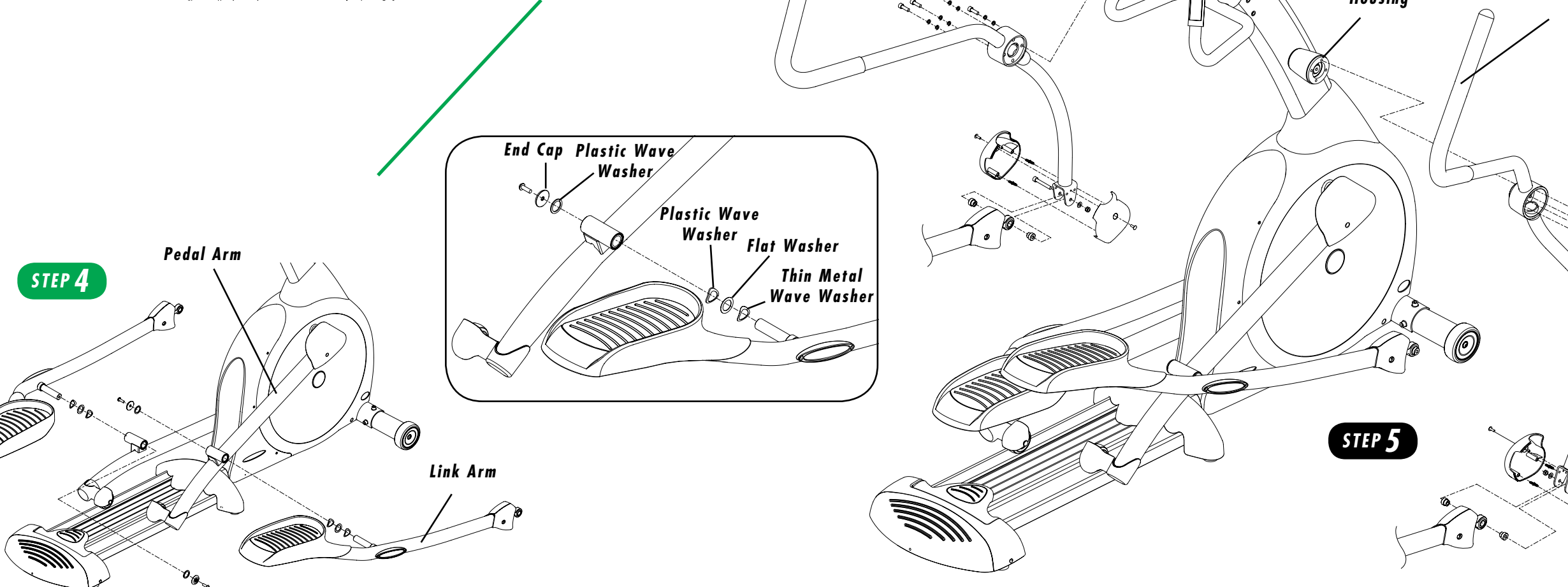
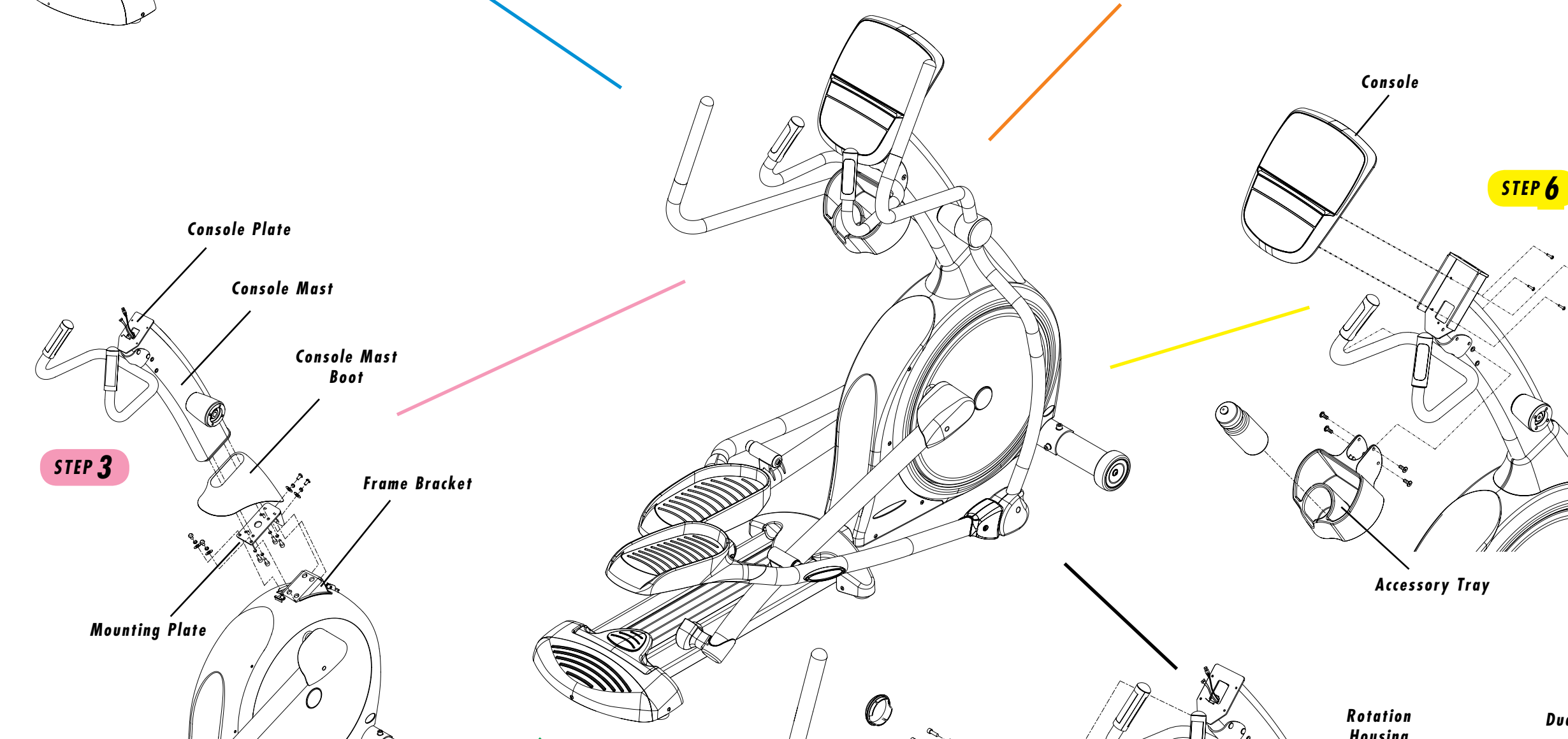
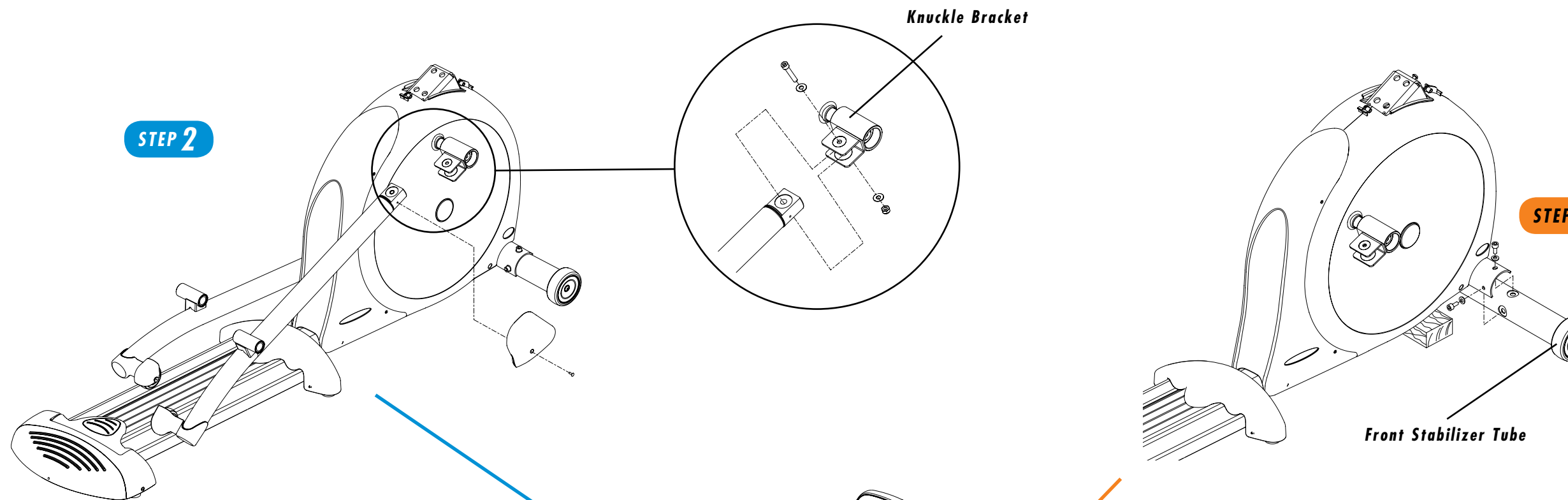

STEP 4 GREEN BAG

- Remove protective covers from sleeves of the pedal arms.
- IMPORTANT:** The washers in the following step must be assembled in the correct order.
- Slide one thin metal wave washer (26x35x0.3T), one flat washer (25.5x38x1T), and one plastic wave washer (25.5x36x2T) onto the axle of the right link arm. Slide the axle of the right link arm through the sleeve on the right pedal arm. Secure the link arm onto the pedal arm with the plastic wave washer (26x36x2T), end cap, and bolt (M8x16L). Tighten with the 5mm L-shaped wrench.
- Repeat the step on the left side.

STEP 5 BLACK BAG

- NOTE:** With this next step it is helpful to have a second person to hold the dual-action arms in place while you assemble them.
- Take the right dual-action arm and center the holes in the rotation housing on the console mast. Secure with four socket head bolts (M8x25L) and four lock washers (M8). Tighten with the 6mm T-shaped wrench.
 - Slide a spacer onto each side of the socket joint located on the end of the link arm. Slide the bottom of the dual-action arm bracket over the link arm socket and spacers. From the outside of the bracket, slide the bolt (M8x55L) through the hole in the bracket and socket joint. Secure with a washer (8x16x1T) and nylon nut (M8). Tighten with the 6mm T-shaped wrench and 13mm wrench.
 - Attach the inside dual-action arm cover onto the bottom of the dual-action arm with a bolt (M5x15L). Insert the plastic connector to the inside dual-action arm cover. Slide the outside dual-action arm cover onto the other end of the plastic connector. Secure the outside dual-action arm cover to the bottom of the dual-action arm with a bolt (M5x15L). Tighten both bolts with the screwdriver.
 - Repeat these steps on the left side.

STEP 6 GREEN BAG

- Slide the accessory tray onto the console mast. Secure in place with four panhead bolts (M8x20L). Tighten with the 5mm L-shaped wrench.
- Remove the four bolts (M5x12L) from the back side of the console. Connect the wire harness and the heart rate wires to the plugs in the back side of the console. Place the console on the mast and secure in place with the bolts (M5x12L).